

PRO COMP

2025-2026 SUSPENSION
PRODUCT CATALOG



CONTENTS

ABOUT	3
GM LIFT KITS	4
FORD LIFT KITS	9
RAM LIFT KITS	12
TOYOTA LIFT KITS	14
JEEP RUBICON EXPRESS EDITION	18
WARRANTY	24
LEGAL	26

ABOUT US

Since our founding in 1985, Pro Comp has been committed to crafting high-quality, durable products for on- and off-road enthusiasts. Our extensive range includes high-performance suspension systems, off-road wheels, lights, and more, all designed with precision and performance in mind.

Our state-of-the-art product design, engineering standards, and manufacturing facilities establish us as a leader in the off-road industry, and continue to set benchmarks for quality, value, and innovation.

In 2011, we proudly expanded our offerings through the acquisition of Rubicon Express, further solidifying our mission to provide top-tier parts for Jeep® enthusiasts at exceptional value. Every component we create is trail-tested, ensuring it meets our rigorous standards for quality, durability, and performance.

At Pro Comp, we prioritize a seamless shopping experience, ensuring that each interaction reflects our unwavering commitment to quality and customer service. We are passionate about empowering you to confidently tackle any adventure, whether on the trail or during your daily commute.

WHY CHOSE PRO COMP

At Pro Comp, we focus on suspension systems, wheels, and lighting to provide an effortless, effective, and economical shopping experience. Our user-friendly, its-all-in-the-box approach makes it easy to find the right products for your vehicle without the hassle. By sticking to the essentials, we deliver what you need quickly and affordably.

We remain committed to advancing the technology of suspension, wheels, and lighting to constantly exceed the demands of modern truck, Jeep, and SUV drivers.

**PRO COMP IS A REGISTERED TRADEMARK OF HOONIGAN.
JEEP IS A REGISTERED TRADEMARK OF STELLANTIS.**





PCSGM126M 6" LIFT KIT

FEATURES:

- New high strength extended steering knuckles for use with 20" + rims retain factory steering geometry and improve ride handling and steering
- 3/16" thick steel front lower crossmembers and differential skid plate add strength to chassis and protection for front differential
- Upper strut spacers retain the factory-tuned struts for same-as-factory ride quality
- FMVSS 126 Certified
- Rear Monotube Shocks*

WHEEL FITMENT:

- Diameter: 20"+
- Width: 9"-10"
- Backspace: 4.5"-5"

* Does not come with shock boots

WARNING: This product can expose you to chemicals including mineral oils which are known to the State of California to cause cancer. For more information go to www.P65Warnings.ca.gov

PART NUM.	YEAR	MAKE	MODEL	2WD/4WD	LIFT	MAX TIRE
PCSGM126M	19-23	CHEV/GMC	1500	4WD	6"	35"



PCSGMLL121 2" LEVELING KIT

FEATURES:

- Provides a leveled stance
- CNC Machined from billet aluminum and designed to install on the bottom of the factory strut
- Features a rugged hammertone powdercoated finish suitable for the harshest conditions

PART NUM.	YEAR	MAKE	MODEL	2WD/4WD	LIFT	MAX TIRE
PCSGMLL121	19-25	CHEV/GMC	1500	4WD	2"	285/70



PCSGMLL122 3" LEVELING KIT

FEATURES:

- Provides the necessary 3 inches of front lift for a level stance on these new generation GM 1500 2WD trucks
- The tapered top spacer helps to correctly position the strut to maximize strut wear over the life of the strut
- Kit includes tapered top mount spacer and lower horse shoe style spacer for a combined 3" of lift

PART NUM.	YEAR	MAKE	MODEL	2WD/4WD	LIFT	MAX TIRE
PCSGMLL122	19-25	CHEV/GMC	1500	2WD	3"	33"

PCSGMLLR123-1 2" REAR BLOCK KIT

FEATURES:

- Comes complete with vehicle specific u-bolts and hardware
- Easy to install. Does not require any permanent modifications
- Adds a nice rake for towing or hauling additional weight in the bed



PART NUM.	YEAR	MAKE	MODEL	2WD/4WD	LIFT
PCSGMLLR123-1	99-24	CHEV/GMC	1500	2WD/4WD	2"

PCSGMLL111 2" LEVELING KIT

FEATURES:

- CNC Machined from billet aluminum and designed to install on the bottom of the factory strut
- Features a rugged hammertone powdercoated finish suitable for the harshest conditions



PART NUM.	YEAR	MAKE	MODEL	2WD/4WD	LIFT	MAX TIRE
PCSGMLL111	07-18	CHEV/GMC	1500	2WD/4WD	2"	33"

PCSGMLL421 1.25" LEVELING KIT

FEATURES:

- Provides a leveled stance
- CNC Machined from billet aluminum and designed to install on the top of the factory strut
- No cutting bolts. Easy to install in just an hour.



PART NUM.	YEAR	MAKE	MODEL	2WD/4WD	LIFT	MAX TIRE
PCSGMLL421	15-22	CHEV/GMC	CANYON/ COLORADO	2WD/4WD	1.25"	32"



PCSGMLL113 2.25" LEVELING KIT

FEATURES:

- CNC machined billet aluminum leveling kit is a top and bottom strut extension leveling kit
- Easy installation in less than 2 hours
- Kit will allow you to run up to 33" tires

PART NUM.	YEAR	MAKE	MODEL	2WD/4WD	LIFT	MAX TIRE
PCSGMLL113	07-18	CHEV/GMC	1500	2WD/4WD	2.25"	33"



PCSGM226M 5.5" LIFT KIT

FEATURES:

- Bolt-on installation
- High strength extended steering knuckles
- High clearance one-piece crossmembers
- Monotube front and rear shock*

WHEEL FITMENT:

- Diameter: 18"+
- Width: 8"-9"
- Backspace: 5.75"-6.125"

* Does not come with shock boots

WARNING: This product can expose you to chemicals including mineral oils which are known to the State of California to cause cancer. For more information go to www.P65Warnings.ca.gov

PART NUM.	YEAR	MAKE	MODEL	2WD/4WD	LIFT	MAX TIRE
PCSGM226M	20-24	CHEV/GMC	2500HD	4WD	5.5"	37"



PCSGMLL231 2" LEVELING KIT

FEATURES:

- Maintains the factory ride and handling
- Delivers clearance for up to 35" tires
- Does not work with AT4X or ZR2 models

PART NUM.	YEAR	MAKE	MODEL	2WD/4WD	LIFT	MAX TIRE
PCSGMLL231	20-24	CHEV/GMC	2500/3500HD	4WD	2"	35"

PCSGMLLR223-2 1" REAR BLOCK KIT

FEATURES:

- Comes complete with vehicle specific u-bolts and hardware
- Easy to install. Does not require any permanent modifications
- Adds a nice rake for towing or hauling additional weight in the bed



PART NUM.	YEAR	MAKE	MODEL	2WD/4WD	LIFT
PCSGMLLR223-2	11-24	CHEV/GMC	2500HD	2WD/4WD	1"

PCSGM216M 7" LIFT KIT

FEATURES:

- Durable Powder Coat Finish
- High strength extended steering knuckles
- High clearance one-piece crossmembers
- Includes front & rear monotube shocks
- FMVSS 126 certified

WHEEL FITMENT:

- Diameter: 17"+
- Width: 9"-10"
- Backspace: 4.5"-6.125"



WARNING: This product can expose you to chemicals including mineral oils which are known to the State of California to cause cancer. For more information go to www.P65Warnings.ca.gov

PART NUM.	YEAR	MAKE	MODEL	2WD/4WD	LIFT	MAX TIRE
PCSGM216M	11-19	CHEV/GMC	2500HD	2WD/4WD	7"	37"

PCSGMLL223 2.25" LEVELING KIT

FEATURES:

- Includes shock mount extension spacers
- Provides a leveled stance
- Safely raises trucks 2.25 inches



PART NUM.	YEAR	MAKE	MODEL	2WD/4WD	LIFT	MAX TIRE
PCSGMLL223	11-19	CHEV/GMC	2500/3500HD	2WD/4WD	2.25"	33"

PCSGMLL213 2.5" LEVELING KIT

FEATURES:

- Includes shock mount extensions and hardware
- Provides a leveled stance
- Lifts the Front to allow for larger wheels and tires



PART NUM.	YEAR	MAKE	MODEL	2WD/4WD	LIFT	MAX TIRE
PCSGMLL213	00-10	CHEV/GMC	2500/3500HD	2WD/4WD	2.5"	33"





PCSFDLLR123 1 1/3" REAR BLOCK KIT

FEATURES:

- Includes factory style bump stop landing and location pins
- Adds a nice rake for towing or hauling additional weight in the bed
- Easy to install. Does not require any permanent modifications

NOTE: IMAGE SHOWN MAY NOT BE EXACT IMAGE OF THE PRODUCTS BELOW

PART NUM.	YEAR	MAKE	MODEL	2WD/4WD	LIFT
PCSFDLLR123-1	04-20	FORD	F-150	2WD/4WD	1"
PCSFDLLR123-3	04-20	FORD	F-150	4WD	3"



PCSF216M 6" LIFT KIT

FEATURES:

- Improves load capacity while maintaining Factory ride quality
- Complete with vehicle specific heavy-duty u-bolts and hardware
- Includes front & rear monotube shocks*
- New high strength radius arms
- FMVSS 126 certified

WHEEL FITMENT:

- Diameter: 18"+
- Width: 9"-10"
- Backspace: 4.75"-5.5"

* Does not come with shock boots

WARNING: This product can expose you to chemicals including mineral oils which are known to the State of California to cause cancer. For more information go to www.P65Warnings.ca.gov

PART NUM.	YEAR	MAKE	MODEL	2WD/4WD	LIFT	MAX TIRE
PCSF216M	17-22	FORD	F-250/350	4WD	6"	37"

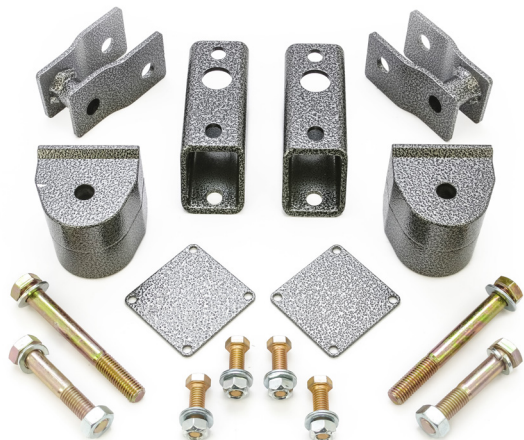

PCSFDLL221 2.5" LEVELING KIT

FEATURES:

- Includes front shock relocation brackets, brake line drop brackets and even front sway bar drop brackets
- No cutting. No modifying. Easy Installation.
- High-quality hammertone powdercoated CNC machined billet aluminum lower coil spring suspension spacers

PART NUM.	YEAR	MAKE	MODEL	2WD/4WD	LIFT	MAX TIRE
PCSFDLL221	04-24	FORD	F-250/350	4WD	2.5"	35"

PCSFDLLR221-4 4" REAR BLOCK KIT

FEATURES:

- Complete with vehicle specific heavy-duty u-bolts and hardware
- Easy to install. Does not require any permanent modifications
- Factory style construction includes integrated bump stop landings and location pins



PART NUM.	YEAR	MAKE	MODEL	2WD/4WD	LIFT
PCSFDLLR221-4	11-24	FORD	F-250/350	2WD/4WD	4"

PCSFDLLR211-4 4" REAR BLOCK KIT

FEATURES:

- Adds a nice rake for towing or hauling additional weight in the bed
- Factory style construction includes integrated bump stop landings and location pins
- Easy to install. Does not require any permanent modifications.
- For trucks with one-piece driveshafts



PART NUM.	YEAR	MAKE	MODEL	2WD/4WD	LIFT
PCSFDLLR211-4	99-10	FORD	F-250/350	2WD/4WD	4"



PCSRAM126M 6" LIFT KIT

FEATURES:

- Enhanced steering geometry and improved turning radius
- New knuckle design helps maintain OEM operating angles of critical components
- Rear geometry correction brackets and coil spacers maintain the factory load carrying capacity
- Includes rear monotube shocks*
- FMVSS 126 certified

WHEEL FITMENT:

- Diameter: OE+
- Width: 8"-9"
- Backspace: 4"-5"

* Does not come with shock boots

WARNING: This product can expose you to chemicals including mineral oils which are known to the State of California to cause cancer. For more information go to www.P65Warnings.ca.gov

PART NUM.	YEAR	MAKE	MODEL	2WD/4WD	LIFT	MAX TIRE
PCSRAM126M	19-24	RAM	1500	4WD	6"	35"



PCSRAMLL133 2" LEVELING KIT

FEATURES:

- Tough fabricated steel front strut pre-load spacers
- This is a great way to add 2" of front leveling lift height while allowing for a 33" tall tire
- Provides a leveled stance

PART NUM.	YEAR	MAKE	MODEL	2WD/4WD	LIFT	MAX TIRE
PCSRAMLL133	19-24	RAM	1500	2WD/4WD	2"	33"



PCSRAMLL121 2.5" LEVELING KIT

FEATURES:

- Laser cut from high quality steel and protected with a rugged and tough hammertone powdercoated finish.
- True bolt on application - no modifications required.
- Install larger wheels and tires (up to 35") while keeping the factory ride.

PART NUM.	YEAR	MAKE	MODEL	2WD/4WD	LIFT	MAX TIRE
PCSRAMLL121	06-24	RAM	1500	4WD	2.5"	35"

PCSRAMLL112 2" LEVELING KIT

FEATURES:

- Tough CNC machined aircraft-grade billet aluminum spacer with a polyurethane sound isolator
- A great way to add 2" of front leveling lift height while allowing for a 33" tall tire
- Designed specifically for the 2WD coil spring front suspension trucks



PART NUM.	YEAR	MAKE	MODEL	2WD/4WD	LIFT	MAX TIRE
PCSRAMLL112	09-18	RAM	1500	2WD	2"	33"

PCSRAMLL311 2" LEVELING KIT

FEATURES:

- Allows you to install larger wheels and tires as well as keep the factory ride
- 2.0" heavy duty steel coil spring spacer
- High quality coil spring spacers



PART NUM.	YEAR	MAKE	MODEL	2WD/4WD	LIFT	MAX TIRE
PCSRAMLL311	94-12	RAM	2500/3500	4WD	2"	35"
PCSRAMLL311	94-01	RAM	1500	4WD	2"	35"

PCSRAMLL221 1.75" LEVELING KIT

FEATURES:

- Provides up to 1.75" of front leveling lift which gives clearance to add up to 35" wheels and tires.
- Manufactured from rugged plate steel with a tough hammertone powder coat finish.
- Not Compatible with Power Wagon or Snow Prep/Ambulance Package.



PART NUM.	YEAR	MAKE	MODEL	2WD/4WD	LIFT	MAX TIRE
PCSRAMLL221	14-24	RAM	2500	4WD	1.75"	35"
PCSRAMLL221	13-24	RAM	3500	4WD	1.75"	35"



PCSTOYLL121 1.5" LEVELING KIT

FEATURES:

- Ships fully assembled with studs pressed in
- Fabricated steel front strut spacers
- Does not fit TRD Pro and Hybrid applications

PART NUM.	YEAR	MAKE	MODEL	2WD/4WD	LIFT	MAX TIRE
PCSTOYLL121	24	TOYOTA	TACOMA	2WD/4WD	1.5"	33"



PCSTOY126M 6" LIFT KIT

FEATURES:

- Includes new high strength extended steering knuckles retains factory steering geometry
- Rear monotube shocks*
- Vehicle specific rear blocks & add-a-leaf
- Heavy duty front and rear one-piece crossmembers
- FMVSS 126 certified

WHEEL FITMENT:

- Diameter: 18"+
- Width: 8"-9"
- Backspace: 4"-5"

* Does not come with shock boots

⚠ WARNING: This product can expose you to chemicals including mineral oils which are known to the State of California to cause cancer. For more information go to www.P65Warnings.ca.gov

PART NUM.	YEAR	MAKE	MODEL	2WD/4WD	LIFT	MAX TIRE
PCSTOY126M	16-23	TOYOTA	TACOMA	4WD	6"	35"



PCSTOYLL111 2.25" LEVELING KIT

FEATURES:

- 2.25" strut suspension extension leveling kit will allow you to have a level stance and increased wheel and tire clearance
- For use on 2WD 6-Lug Tacoma Pre-Runners
- High-quality hammertone powdercoated laser cut steel strut suspension spacers

PART NUM.	YEAR	MAKE	MODEL	2WD/4WD	LIFT	MAX TIRE
PCSTOYLL111	05-23	TOYOTA	TACOMA 6-LUG	2WD	2.25"	33"

PCSTOYLL112 2.25" LEVELING KIT

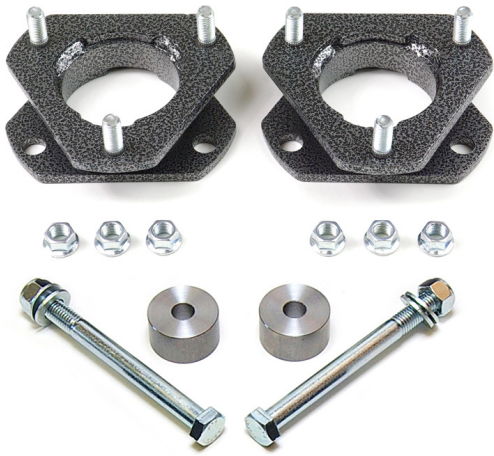

FEATURES:

- 2.25" strut suspension extension leveling kit will allow you to have a level stance and increased wheel and tire clearance
- High-quality hammertone powdercoated laser cut steel strut suspension spacers
- Includes diff. drop.
- No cutting. No modifying. Easy Installation in less than two hours!

PART NUM.	YEAR	MAKE	MODEL	2WD/4WD	LIFT	MAX TIRE
PCSTOYLL112	05-23	TOYOTA	TACOMA	4WD	2.25"	33"
PCSTOYLL112	03-24	TOYOTA	4RUNNER	4WD	2.25"	33"
PCSTOYLL112	05-14	TOYOTA	FJ CRUISER	4WD	2.25"	33"

PCSTOYLLR31-1 1" REAR BLOCK KIT



FEATURES:

- Comes complete with vehicle specific u-bolts and hardware
- Adds a nice rake for towing or hauling additional weight in the bed
- Easy to install. Does not require any permanent modifications

PART NUM.	YEAR	MAKE	MODEL	2WD/4WD	LIFT
PCSTOYLLR31-1	95-23	TOYOTA	TACOMA	2WD/4WD	1"

PCSTOYLLR31-2 2" REAR BLOCK KIT

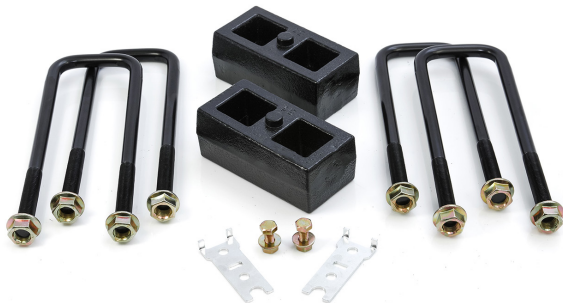

FEATURES:

- Comes complete with brake line extension brackets, vehicle specific u-bolts and hardware
- Adds a nice rake for towing or hauling additional weight in the bed
- Easy to install. Does not require any permanent modifications

PART NUM.	YEAR	MAKE	MODEL	2WD/4WD	LIFT
PCSTOYLLR31-2	95-23	TOYOTA	TACOMA	2WD/4WD	2"

PCSTOY116M 6" LIFT KIT

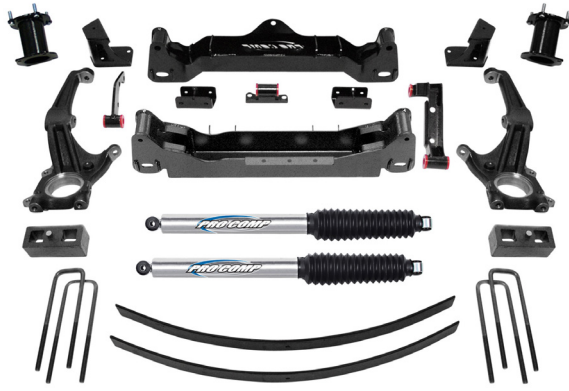

FEATURES:

- 3/16" thick steel front lower crossmember
- Upper strut spacers retain factory tuned struts
- New high strength extended steering knuckles
- Rear monotube shocks*
- FMVSS 126 certified

WHEEL FITMENT:

- Diameter: 18"+
- Width: 8"-9"
- Backspace: 4"-5"

* Does not come with shock boots

WARNING: This product can expose you to chemicals including mineral oils which are known to the State of California to cause cancer. For more information go to www.P65Warnings.ca.gov

PART NUM.	YEAR	MAKE	MODEL	2WD/4WD	LIFT	MAX TIRE
PCSTOY116M	05-15	TOYOTA	TACOMA	2WD/4WD	6"	35"

PCSTOY226M 6" LIFT KIT

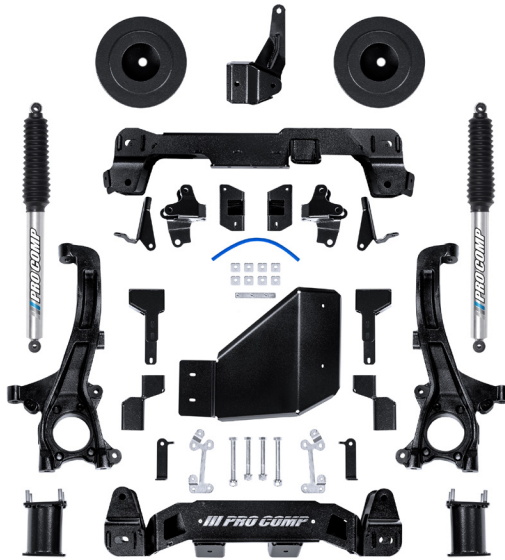

FEATURES:

- New high strength extended steering knuckles
- Diff. Drop Brackets
- Rear monotube shocks*
- Upper strut spacers retain factory tuned struts
- Not compatible with Air Ride Suspension
- FMVSS 126 certified

WHEEL FITMENT:

- Diameter: 20"+
- Width: 9"
- Backspace: 5.34" on 35" - 5.5" on 37"

* Does not come with shock boots

WARNING: This product can expose you to chemicals including mineral oils which are known to the State of California to cause cancer. For more information go to www.P65Warnings.ca.gov

PART NUM.	YEAR	MAKE	MODEL	2WD/4WD	LIFT	MAX TIRE
PCSTOY226M	22-24	TOYOTA	TUNDRA	2WD/4WD	6"	37"

PCSTOYLL221 2" LEVELING KIT



FEATURES:

- Fabricated steel front strut spacers with durable black powder coat finish
- Drops front differential to provide better maximum operating angle for CV joints
- 100% Bolt-on with no cutting or welding
- Includes diff. drop.

PART NUM.	YEAR	MAKE	MODEL	2WD/4WD	LIFT	MAX TIRE
PCSTOYLL221	22-24	TOYOTA	TUNDRA	2WD/4WD	2"	33"

PCSTOYLL213 2.25" LEVELING KIT

FEATURES:

- High-quality hammertone powdercoated laser cut steel strut suspension spacers offer a full 2.5" of front lift and the ability to install up to 33" tires
- No cutting, No modifying, Easy Installation
- Includes diff. drop.
- Note: Not for use on TRD Pro

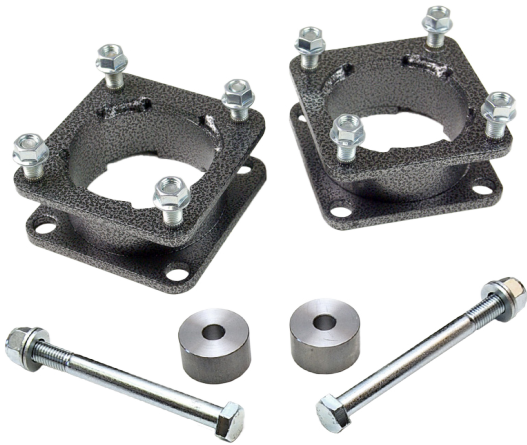

PART NUM.	YEAR	MAKE	MODEL	2WD/4WD	LIFT	MAX TIRE
PCSTOYLL213	07-21	TOYOTA	TUNDRA	2WD/4WD	2.25"	33"

PCSTOYLLR31-1 1" REAR BLOCK KIT

FEATURES:

- Comes complete with vehicle specific u-bolts and hardware
- Adds a nice rake for towing or hauling additional weight in the bed
- Easy to install. Does not require any permanent modifications.



PART NUM.	YEAR	MAKE	MODEL	2WD/4WD	LIFT
PCSTOYLLR31-1	99-21	TOYOTA	TUNDRA	2WD/4WD	1"

PCSTOYLLR31-2 2" REAR BLOCK KIT

FEATURES:

- Comes complete with brake line extension brackets, vehicle specific u-bolts and hardware
- Adds a nice rake for towing or hauling additional weight in the bed
- Easy to install. Does not require any permanent modifications.

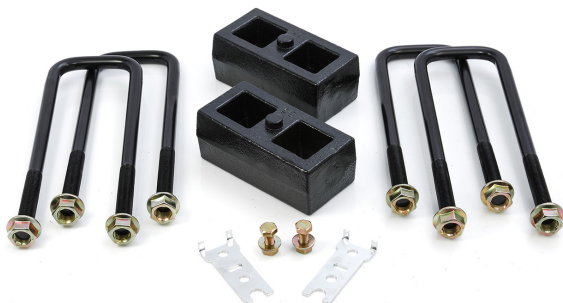

PART NUM.	YEAR	MAKE	MODEL	2WD/4WD	LIFT
PCSTOYLLR31-2	99-21	TOYOTA	TUNDRA	2WD/4WD	2"

RUBICON EXPRESS

DRIVEN BY ADVENTURE, BUILT FOR THE TOUGHEST TRAILS

Since 1996, Rubicon Express has been on a mission to revolutionize off-road adventures. Founded by Rustin Smith, we set out with a clear goal: to deliver Jeep enthusiasts the ultimate suspension systems that can conquer the most demanding trails and terrains. What started as a passion project has grown into an iconic name trusted by off-roaders worldwide.

A LEGACY OF INNOVATION AND PERFORMANCE

Over the years, Rubicon Express has earned its stripes in the off-road community. From pioneering new suspension designs to delivering unmatched durability, we've built a reputation for going above and beyond—literally. Our products don't just meet expectations; they exceed them, helping you push your Jeep to the limit with confidence.

A GAME-CHANGING PARTNERSHIP

In 2011, our journey took an exciting turn when we joined forces with Pro Comp. This partnership wasn't just about combining brands—it was about uniting expertise. Together, we've set a new industry standard, blending precision engineering with trail-tested performance to create products that elevate your off-road experience.

INTRODUCING THE RUBICON EXPRESS EDITION JEEP KITS BY PRO COMP

Today, we're proud to offer a line of suspension systems that represents the pinnacle of off-road engineering: the Rubicon Express Edition Jeep Kits. These systems are crafted by an integrated team of experts who share a passion for innovation and an obsession with quality. Designed to handle the toughest terrain and enhance every adventure, these kits are the ultimate companion for your Jeep.

FUELED BY PASSION, BUILT FOR ADVENTURE

At Rubicon Express by Pro Comp, we don't just build suspension systems—we build confidence, freedom, and the spirit of adventure. Whether you're tackling rocky trails, conquering steep inclines, or cruising through the backcountry, we're here to ensure your Jeep performs at its best every mile of the way.

Ready to take your Jeep to the next level? Join the Rubicon Express family, where craftsmanship meets adventure, and every road leads to something extraordinary.

WHEN THERE'S NO TURNING BACK™

CATEGORIES

KITS AVAILABLE FOR JT, JT, JK & TJ

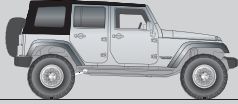

- 2" - 2.5" of lift
- Bolt on installation
- Allows for more ground clearance
- Allows for use of larger tires



SPACER KIT

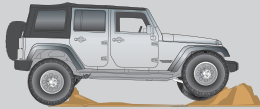

- Replacement Coils
- Bolt on installation
- Increases height for larger tires

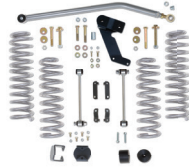

STANDARD KIT

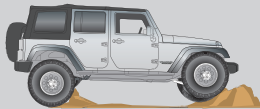

- 3.5" front & rear replacement coil springs
- High steer kit
- Control arm geometry correction bracket
- Premium on road performance



SPORT KIT

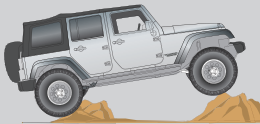

- Short arm suspension
- Bolt on installation
- Increases suspension travel
- Rebuildable/serviceable Super-Flex joints
- Increases articulation



SUPER-FLEX KIT



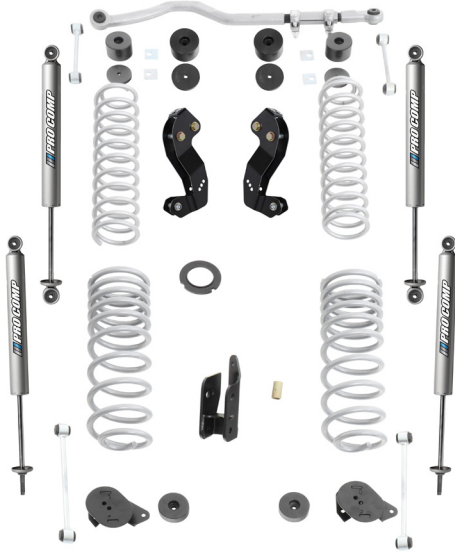

PCSRUEJT435M 2.5/3.5" SPORT KIT

FEATURES:

- Control arm geometry correction brackets
- Front and rear replacement coil springs
- Cam bolts for caster and pinion adjustment
- Bump stops
- Rear track bar bracket
- Extended sway bar end links
- Includes front & rear monotube shocks
- Does not fit Diesel models
- 2.5" lift on Rubicon
- 3.5" lift on non Rubicon

⚠WARNING: This product can expose you to chemicals including mineral oils which are known to the State of California to cause cancer. For more information go to www.P65Warnings.ca.gov

PART NUM.	YEAR	MAKE	MODEL	LIFT	MAX TIRE	REC. WHEEL
PCSRUEJT435M	20-24	JEEP	JT GLADIATOR	2.5/3.5"	35X12.50	9" WIDE 3.75-4.5" BS



PCSRUEJT455M 4.5-5.5" SPORT KIT W/ GCB

FEATURES:

- Front replacement coil springs
- Rear multi-rate coil springs to maintain factory tow ratings, while providing a comfortable ride
- Front and rear bump stops
- Rear track bar bracket for improved handling
- Adjustable front track bar
- Front driveshaft and yoke adapter
- Extended front and rear coated stainless steel braided brake lines
- Extended sway bar end links
- Includes front & rear monotube shocks
- Does not fit Diesel models
- 4.5" lift on Rubicon models
- 5.5" lift on non Rubicon models

⚠WARNING: This product can expose you to chemicals including mineral oils which are known to the State of California to cause cancer. For more information go to www.P65Warnings.ca.gov

PART NUM.	YEAR	MAKE	MODEL	LIFT	MAX TIRE	REC. WHEEL
PCSRUEJT455M	20-24	JEEP	JT GLADIATOR	4.5/5.5"	37X13.50	9" WIDE 3.75-4.5" BS



PCSRUEJT42E 2" SPACER KIT

FEATURES:

- Includes front shock extensions
- 2" steel coil spring spacers to level out the OE rake with index pins and holes to locate factory isolators for OEM spring alignment
- Bolt-in rear bump stop extensions maintain clearance for 35" tires on Sport models (37" tires on Rubicon models) during off road activity
- Sway bar drops maintain geometry for optimal operating angle
- No driveline or exhaust modifications required

PART NUM.	YEAR	MAKE	MODEL	LIFT	MAX TIRE	REC. WHEEL
PCSRUEJT42E	20-24	JEEP	JT GLADIATOR	2"	35X12.50	9" WIDE 3.75-4.5" BS

PCSRUEJL425M 2.5" STANDARD COIL KIT



FEATURES:

- Custom tuned coil springs based off of factory rate to provide OE ride handling characteristics
- Extended length end links for proper sway bar geometry
- Clears 35" tires on loaded non-Rubicon models and 37" tires on Rubicon models
- Front and rear mono tube shocks*

*Does not come with shock boots

WARNING: This product can expose you to chemicals including mineral oils which are known to the State of California to cause cancer. For more information go to www.P65Warnings.ca.gov

PART NUM.	YEAR	MAKE	MODEL	LIFT	MAX TIRE	REC. WHEEL
PCSRUEJL425M	18-24	JEEP	JL WRANGLER	2.5"	35X12.50	9" WIDE 3.75-4.5" BS

PCSRUEJL435M 3.5/4.5" STANDARD COIL KIT

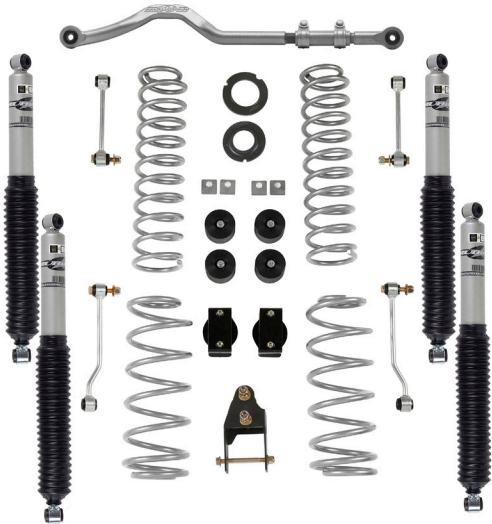

FEATURES:

- Custom tuned coil springs based off of factory rate to provide OE ride handling characteristics
- Extended rear sway bar links for proper geometry
- Clears 35" tires on loaded non-Rubicon models and 37" tires on Rubicon models
- Front and rear mono tube shocks*
- Rear track bar bracket
- 3.5" on Rubicon
- 4.5" on non Rubicon

*Does not come with shock boots

WARNING: This product can expose you to chemicals including mineral oils which are known to the State of California to cause cancer. For more information go to www.P65Warnings.ca.gov

PART NUM.	YEAR	MAKE	MODEL	LIFT	MAX TIRE	REC. WHEEL
PCSRUEJL435M	18-24	JEEP	JL WRANGLER	3.5/4.5"	35X12.50	9" WIDE 3.75-4.5" BS

PCSRUEJL42E 2" SPACER KIT

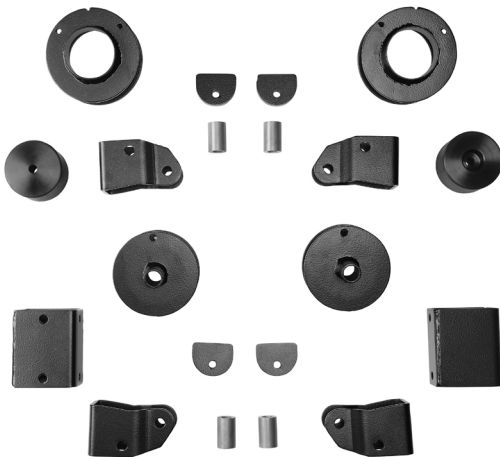

FEATURES:

- Steel coil spring spacers with index pins and holes to locate
- Factory isolators for perfect spring alignment
- Bolt-in bump stop extensions maintain clearance for 35" tires
- Includes front & rear shock extensions

PART NUM.	YEAR	MAKE	MODEL	LIFT	MAX TIRE	REC. WHEEL
PCSRUEJL42E	18-24	JEEP	JL WRANGLER	2"	35X12.50	9" WIDE 3.75-4.5" BS

PCSRUEJK43M 3.5" SPORT COIL KIT



FEATURES:

- High steer kit
- Control arm geometry correction brackets
- 3.5" front and rear replacement coil springs
- Front and rear cam bolts for caster and pinion adjustment
- Bump stops
- Rear track bar bracket
- Extended rear sway bar end links
- Easily upgradeable to the Super-Flex kit
- Front and rear mono tube shocks*
- 2012 and newer will require exhaust mod or front drive shaft

* Does not come with shock boots

WARNING: This product can expose you to chemicals including mineral oils which are known to the State of California to cause cancer. For more information go to www.P65Warnings.ca.gov

PART NUM.	YEAR	MAKE	MODEL	LIFT	MAX TIRE	REC. WHEEL
PCSRUEJK43M	07-18	JEEP	JK WRANGLER	3.5"	35X12.50	9" WIDE 3.75-4.5" BS

PCSRUEJK235M/RUEJK435M 3.5" SUPER FLEX KIT

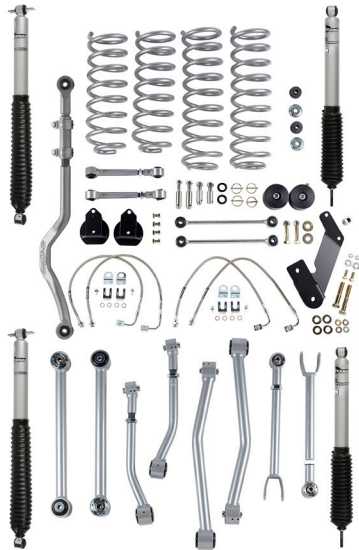

FEATURES:

- Short arm system
- New PT-Meg Super-Ride bushings, Designed for on and off-road performance
- Adjustable upper control arms and Fixed lower control arms with serviceable Super-Flex spherical ball joints
- Front and rear mono tube shocks*
- 2012 and newer may require exhaust mod or front drive shaft

* Does not come with shock boots

WARNING: This product can expose you to chemicals including mineral oils which are known to the State of California to cause cancer. For more information go to www.P65Warnings.ca.gov

PART NUM.	YEAR	MAKE	MODEL	LIFT	MAX TIRE	REC. WHEEL
PCSRUEJK235M	07-18	JEEP	2 DR. JK WRANGLER	3.5"	35X12.50	9" WIDE 3.75-4.5" BS
PCSRUEJK435M	07-18	JEEP	4 DR. JK WRANGLER	3.5"	35X12.50	9" WIDE 3.75-4.5" BS

PCSRUEJK52E 2.5" SPACER KIT

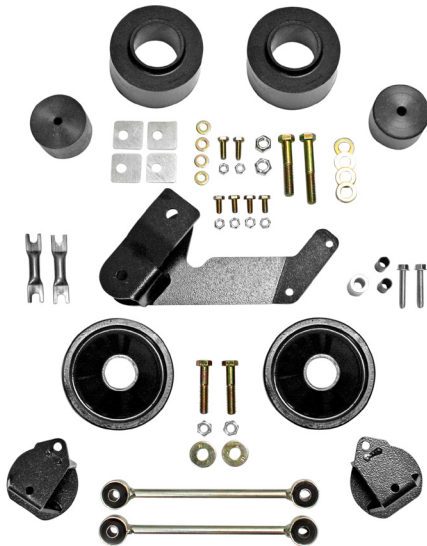

FEATURES:

- 2.5" leveling kit
- Front bump stops
- Rear bump stop pads
- Rear track bar bracket
- Includes front & rear shock extensions

PART NUM.	YEAR	MAKE	MODEL	LIFT	MAX TIRE	REC. WHEEL
PCSRUEJK52E	07-18	JEEP	JK WRANGLER	2.5"	35X12.50	9" WIDE 3.75-4.5" BS

RUETJ22M 2" SPACER KIT

FEATURES:

- 2" of lift
- Rear bump stops
- Precision-valved twin tube shocks
- Easy installation



WARNING: This product can expose you to chemicals including mineral oils which are known to the State of California to cause cancer. For more information go to www.P65Warnings.ca.gov

PART NUM.	YEAR	MAKE	MODEL	LIFT	MAX TIRE	REC. WHEEL
PCSRUETJ22M	97-06	JEEP	TJ WRANGLER	2"	31X10.50	8" WIDE 3.75-4.5" BS

EXTREME DUTY JT/JL/JK FORGED ADJUSTABLE FRONT TRACK BAR



The Rubicon Express JK, JL & JT Wranglers front forged track bar features a heat treated steel construction designed to eliminate deflection caused by oversized tires or extreme side load. It features an adjustable sleeved collar which allows for precise axle alignment while still on the vehicle preventing the need to disassemble the suspension as well as OE style bushings.

PART NUM.	DESCRIPTION
PCSRUERE1689	FORGED TRACK BAR FRONT JT/ JL/ JK 0"-6"

SUPER-FLEX JOINTS

The Super Flex Joints are standard equipment in Rubicon Express Super Flex systems. This cartridge is UHMW races and a machined end ring which allows for easy tightening or rebuilding when necessary.



PART NUM.	DESCRIPTION	PART NUM.	DESCRIPTION
PCSRUERE3797	SUPER-FLEX JOINT ASSEMBLY RACE - LARGE PAIR	PCSRUERM10200	LOWER CONTROL ARM BUSHING SLEEVE
PCSRUERE3792	SUPER-FLEX JOINT ASSEMBLY - LARGE	PCSRUERM40560	XJ SHACKLE BUSHING
PCSRUERE3791	SUPER-FLEX JOINT ASSEMBLY - SMALL	PCSRUERM42045	LG S/R PTMEG 88A BUSHING
PCSRUERE3798	SUPER-FLEX JOINT ASSEMBLY RACE - SMALL PAIR	PCSRUERM42047	MED S/R PTMEG BUSHING
PCSRUERM13700	SUPER-FLEX JOINT SPHERICAL BALL	PCSRUERM42055	SM S/R PTMEG 88A BUSHING
PCSRUERM10190	UPPER CONTROL ARM BUSHING SLEEVE		



THE PRO COMP PROMISE WARRANTY

At Pro Comp, we know you have many choices when selecting products to personalize your vehicle. You should demand nothing but the highest quality available and have total confidence that the products you selected are the best in the industry. It is for these reasons that Pro Comp Suspension products are backed by the best warranty in the industry...the Pro Comp Promise! Because of our commitment to quality and manufacturing excellence, we are able to stand behind our products, WHETHER YOU ARE THE ORIGINAL PURCHASER OR NOT. It is Pro Comp's Promise that if one of our suspension products breaks not due to misuse, neglect or vandalism, we will replace it. That's our Pro Comp Promise!

NOTICE TO OWNER, OPERATOR, DEALER AND INSTALLER

Vehicles that have been enhanced for off-road performance often have unique handling characteristics due to the higher center of gravity and larger tires. This vehicle may handle, react and stop differently than many passenger cars or unmodified vehicles, both on and off-road. You must drive your vehicle safely! Extreme care should always be taken to prevent vehicle rollover or loss of control, which can result in serious injury or even death. Always avoid sudden sharp turns or abrupt maneuvers and allow more time and distance for braking! Pro Comp reminds you to fasten your seat belts at all times and reduce speed! We will gladly answer any questions concerning the design, function, maintenance and correct use of our products.

Please make sure that the Dealer / Installer explains and delivers all warning notices, warranty forms and instruction sheets included with Pro Comp product.

WARRANTY AND RETURN POLICY

Pro Comp warrants its full line of products to be free from defects in workmanship and materials for the life of the product. Pro Comp's obligation under this warranty is limited to repair or replacement, at Pro Comp's option, of the defective product. Any and all costs of removal, installation, freight or incidental or consequential damages are expressly excluded from this warranty. Pro Comp is not responsible for damages and / or warranty of other vehicle parts related or non-related to the installation of Pro Comp product. A consumer who makes the decision to modify his vehicle with aftermarket components of any kind will assume all risk and responsibility for potential damages incurred as a result of their chosen modifications. Warranty coverage does not include consumer opinions regarding ride comfort, fitment and design. Warranty claims can be made directly with Pro Comp or at any factory authorized Pro Comp dealer.

CLAIMS NOT COVERED UNDER PROCOMP PROMISE WARRANTY

- Bushings, bump stops, ball joints, tie rod ends and heim joints: 1 Year warranty
- Leaf Springs & Coil Springs: 5 Year Warranty due to sagging
- Shock Absorbers: 3 Year Warranty due to leaking and diminished dampening
- Finish after 90 days.
- Damage caused as a result of not following recommendations or requirements called out in the installation manuals.

Pro Comp accepts no responsibility for any altered product, improper installation, lack of or improper maintenance or improper use of our products.

THE LIFT SHIELD WARRANTY

WHAT IS COVERED

- **ENGINE**

All internal lubricated parts, timing belt, pulleys and cover; oil pump; water pump; manifolds; harmonics balancer; engine mounts; turbocharger housing, internal parts and vanes. Note: Cases, housings engine block and cylinder heads are only covered if damaged by the failure of an internal lubricated part.

- **AUTOMATIC TRANSMISSION/TRANSFER CASE**

All internal lubricated parts, torque converter, vacuum modulator.

- **MANUAL TRANSMISSION/TRANSFER CASE**

All internal lubricated parts. Does not include manual clutch, pressure plate, throw-out bearings, pilot bearing or bushing, clutch master or slave cylinders.

- **REAR-WHEEL DRIVE**

All internal lubricated parts, propeller shafts, supports and U-joints, axle shafts and bearings.

- **FRONT-WHEEL DRIVE**

All internal lubricated parts, propeller shafts, axle shafts, constant velocity joints, front hub bearings.

Upon payment of the \$100 deductible per visit and before the expiration of this agreement, the necessary repairs to the components listed above will be reimbursed without additional charge to you. Replacement of any part may be made with new parts or parts of like kind and quality at the time of breakdown, at the option of the Manufacturer.

WHAT IS NOT COVERED

This Limited Warranty Agreement will cover only those items listed under "What is Covered", and does not cover the following: Incidental or consequential damages or loss caused by breakdown of components (or otherwise) including property damage, personal injury, inconvenience, loss of vehicle use and commercial loss.

Commercial use is excluded and will void coverage under this Limited Warranty Agreement. Repairs required because of collision, abuse, overheating, or operation without proper lubrication or coolant, road conditions, misuse, negligence, alterations, racing, accidents, fires, floods, riots, acts of God, vandalism, upset, theft, lack of reasonable and proper maintenance, abuse through towing or improper load capacity, abuse through continued operation of an impaired vehicle, or any other losses normally covered by casualty insurance. Repairs that would be covered by the vehicle original manufacturers' warranty unless written evidence is submitted that a claim made under the original manufacturers' warranty was denied due to a lift kit installed by the Seller. Excessive oil consumption, loss of compression, or gradual reduction in operating performance after purchase, any repairs on vehicles whose mileage has been altered or whose odometer has been tampered with. Repairs covered by this Limited Warranty Agreement in excess of the then current NADA wholesale value of your vehicle prior to the breakdown of the covered component. The total of all benefits paid or payable under this Limited Warranty Agreement shall not exceed the price paid for the vehicle. Repairs performed by someone other than the seller. Rental or towing expenses.

- **MECHANICAL**

Service adjustment/cleaning, carburetor, throttle body assembly (except injectors), contaminated fuel system, air conditioning recharge, refrigerant, coolant, battery cables, belts, hoses, brakes (front hubs, drums, shoes, lining, disc rotors and pads), exhaust system (including catalytic converter), filters, fluids, lights (bulbs, sealed beam and lenses), lubricants, manual clutch disc, strut studs, wiper blades, shop supplies and hazardous waste removal. Repairs, retrofit, or replacement of any components caused by or due to compliance with any law or legislation including the 1990 Clean Air Act.

- **EXTERIOR**

Service adjustments (glass and body parts), bright metal, bumpers, body panels, door handles, hinges, glass, moldings, outside ornamentation, convertible or vinyl tops, paint, rust, sheet metal, sideview, mirrors (glass and housing), air and water leaks, weather-strip, wheel covers/ornaments and wind noise. Physical damage, alignment of bumper and body parts. Interior - Buttons, carpet, dash pad, door and window handles, knobs, rearview mirror (glass and housing), trim and upholstery. Radios, tape players, compact disc players, graphic equalizers, speakers, cellular telephones, theft deterrent systems, and radar detectors.

- **MAINTENANCE RESPONSIBILITIES**

Failure to perform the vehicle manufacturer's recommended maintenance will result in loss of your protection under the Limited Warranty Agreement. Maintenance records from the date of the delivery supported by the receipts indicating date, mileage and services performed must be kept by the vehicle purchaser and made available to Manufacturer on request.

- **CHANGE OF VEHICLE OWNERSHIP**

The Coverage provided by this Limited Warranty Agreement applies only to the covered vehicle while owned by the person whose name appears on this agreement. This agreement is non-transferrable.

WHAT TO DO IF REPAIRS ARE NEEDED

Contact the Lift Shield Claims Administration office at (800) 776-0767 for claims authorization. Claims MUST be authorized by the claims office prior to any repair being performed. Customer must have original Proof of Purchase with sku, installation date, and noted odometer reading.

- 5 Year / 60,000 Mile Powertrain Protection
- \$1,500 value FREE
- Easy Registration
- A Pro Comp Exclusive
- Modify Your Vehicle with Confidence
- Have Complete Peace of Mind

THE ULTIMATE PROTECTION FOR YOUR FORD, CHEVROLET, DODGE, AND TOYOTA

Pro Comp is the first aftermarket suspension manufacturer in the United States and Canada that offers Lift Shield - a FREE 5 year / 60,000 mile powertrain warranty on qualifying suspension kits. Lift Shield protects Pro Comp's most popular suspension systems for late model trucks. It also covers powertrain-related components, including the engine, transmission, transfer case, gears and axles. Without this protection repairs to your engine could cost you thousands of dollars. That's why Lift Shield is so valuable - it actually protects the vehicle on which it is installed. No other suspension manufacturer can offer this type of protection and value.

Whether your vehicle is used for towing bikes to the desert or hauling supplies home from the hardware store, you will have total peace of mind when covered by Lift Shield.

VEHICLE MODIFICATION NOTICE

SAFETY WARNING (SAE J2492)

Installing this product modifies your vehicle's suspension, which may result in different handling characteristics from factory-equipped vehicles.

Essential safety precautions:

- Exercise extreme care during sharp turns and sudden maneuvers
- Always wear seat belts
- Reduce speed and use specialized driving techniques
- Familiarize yourself with modified vehicle handling before regular use
- Maintain control under all driving conditions

ROLLOVER RISK WARNING

Modified suspensions and larger tires increase ground clearance and alter handling:

- Vehicle may have increased rollover risk
- Reduced speeds required for safe operation
- Increased braking distances
- Different handling characteristics from stock
- Regular inspection and maintenance required

OPERATING REQUIREMENTS

- Driver and passengers must always wear seat belts
- Avoid sudden maneuvers and sharp turns
- Never operate under the influence of alcohol or drugs
- Maintain awareness of increased blind spots
- Follow all state and local laws regarding vehicle modifications
- Regular maintenance required for safe operation

INSTALLATION REQUIREMENTS

1. Professional alignment required after installation
2. Headlight aim adjustment may be necessary
3. ADAS (Advanced Driver Assistance Systems) recalibration required if equipped
 - May require dealer service tools
 - Factory-trained technician may be needed
 - Additional costs may apply

TRADEMARK NOTICE

Pro Comp® and the Pro Comp logo are registered service marks of Wheel Pros. Pro Comp operates as an independent manufacturer and is not affiliated with:

- Ford Motor Company
- General Motors (Chevrolet & GMC)
- Toyota Motor Sales
- Stellantis (Dodge, Jeep, Ram, Mopar)

All manufacturer names, vehicle models, and terms are used solely for fitment and application purposes. References to OEM brands and models are for descriptive purposes only and comply with Fair Use guidelines.

STATE COMPLIANCE

- Modifications may not be legal in all states
- Buyer responsible for compliance with local laws
- California Proposition 65 Warning: This product can expose you to chemicals known to the State of California to cause cancer
- Additional state-specific restrictions may apply



/// PRO COMP

PROCOMPUSA.COM

